

SURE-LOC® QC™ MODULAR HUNTING SIGHTS

SURE-LOC® QC™ MODULES

The SURE-LOC® QC™ hunting sights use a modular pin block. Using extra QC™ Modules—available separately—allows the archer to quickly change pin set-ups.

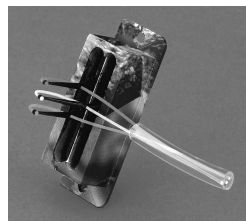

QC™ Module removal (See Figure 5)

1. Remove the (2) #5-40 x 1/4" button head cap screws (J) with a 5/64 hex allen wrench.
2. Take care to protect the fiber optics when removing the module. Slide the module out of the pin guard frame, while carefully pulling the fibers out of the tube mounted in the windage block channel (C). (Do not remove the tube.)

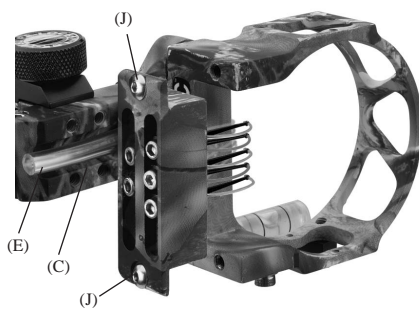

Figure 5

QC™ Module assembly (See Figures 5 and 5A)

1. Place module into the pin guard and install the (2) #5-40 x 1/4" button head cap screws (J).
2. Install the number of pins desired using #4-40 x 5/16" socket head cap screws and a square washer. Alternate pin positions using the front and rear slots, making sure the fiber hole in the pin is facing toward the shooter.
3. Using heat source (do not use open flame) no hotter than 160°F, carefully expand one end of new fiber. A slight flare is enough to keep the fiber from slipping out of the pin.
Note: For best light gathering capabilities, smooth end of fiber while hot.
4. Slip the unexpanded end of the fiber through the end pin hole until the flared end is close to the pin.
5. Insert the fiber through the other pin hole. Gently pull fiber through and carefully push on the looped part of the fiber, until you get a loop that is about 3/16" to 1/4" from back of pin. (Be careful not to kink fiber.)
6. Repeat steps 3-5 for remaining pins.
7. Slide the long end of the fiber through the clear tube (E) in windage block channel (C). It will extend beyond the tube. Trim fiber to desired length.

SURE-LOC® QC™ MODULAR HUNTING SIGHTS

Installing previously assembled QC™ Module (See Figures 5 and 5A)

1. Place the clear tube of the module that you are going to install onto the fibers of the removed module. This will protect the fibers from damage during storage.
2. Slide previously assembled module into pin guard frame, with loose ends of the fiber optics pointing through head towards back of sight.
3. Start the long fiber ends into the tube (E).
4. Re-install the (2) button head cap screws (J).
5. Carefully slide the fiber the rest of the way into the tube.
6. Trim fiber to desired length.

Figure 5A

