

QC[®]

SURE-LOC[®]

ARCHERY PRODUCTS

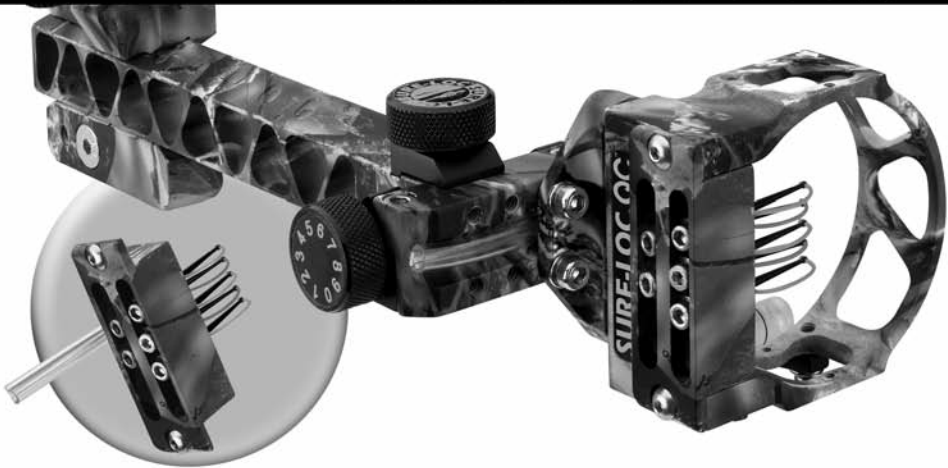

Sight Assembly	2
Mounting Sight on Bow:	
QC [®] 1	2
QC [®] 2	3
QC [®] MAX	3
Set-Up and Adjustment:	
3-Axis Leveling	4
Windage Adjustment	5
Elevation and Pin Adjustment	5
QC Modules:	
Removal	7
Assembly	7
Replacement	8
Lens Adapter/Choke Tube	9
Light Kit	10

INSTALLATION & ADJUSTMENT INSTRUCTIONS

FOR SURE-LOC[®] QC[®]
MODEL 150 & MODEL 200
SIGHTS AND ACCESSORIES

SIGHT ASSEMBLY

Sight body to micro-windage

1. Remove twist-tie. Position tube containing the fiber between the two mounting holes on the offset bracket. Place the tube (E) into the windage block channel (C) with the fibers pointing toward the windage knob (G).

(See Figures 1 and 2)

Note: The offset bracket comes assembled on the sight head and it must be used. It allows the sight head to be mass moved up or down 1 3/4".

2. Insert (2) #6-32 x 3/8" socket head cap screws (F) with flat washers into the mounting slots of the offset bracket. Position the bolts in the center of the mounting slots. Mount the head onto the front of the micro windage unit. Start with the middle holes and move to other holes, if needed. **(Do not over tighten.)**

Note: There are 4 sets of holes to allow mass movement left or right in 15/16" intervals and—with .650" of micro movement—there is a total of 1.50" windage adjustment possible.

3. Trim fiber to desired length.

FIGURE LEGEND

- (A) mounting block
- (B) windage clamp knob
- (C) windage block channel
- (D) level holder screws
- (E) fiber tube
- (F) windage screws
- (G) windage knob
- (H) elevation screws
- (I) offset bracket screws
- (J) module screws
- (K) pin adjustment track
- (L) slide lock knob
- (M) stop knob

Mounting sight on bow

SURE-LOC® QC® 1

1. Install mounting block (A) on bow with (2) #10-24 x 7/8" flathead allen screws provided. **(See Figure 1)**
2. Insert extension into mounting block and secure it by turning the mounting block knob into one of the detents until snug. The two tapped holes are for a quiver mount bracket, if needed. (Use the provided quiver mount spacers.)

For left-handed set-up:

1. Install mounting block (A) on bow with (2) #10-24 x 7/8" flathead allen screws provided, with the mounting block knob facing down and the tapped quiver mount holes toward the back of the bow.

2. Insert extension into mounting block and secure it by turning the mounting block knob into one of the detents until snug.

3. Remove the (2) level holder screws (D) (#5-40 x 5/16" socket head cap screws) from pin guard and reinstall them with the level and holder on the opposite side.

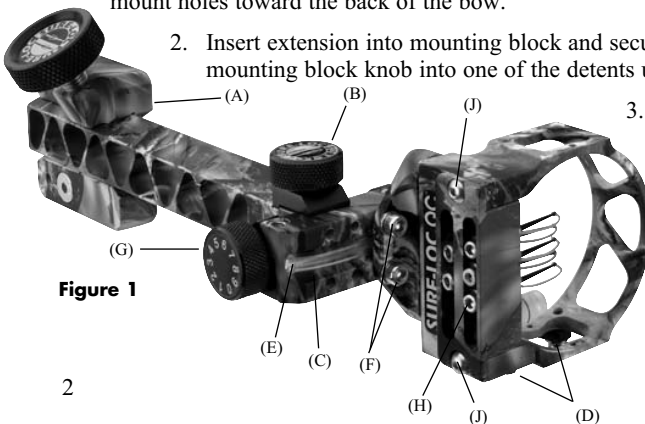

Figure 1

SURE-LOC® QC® 2

1. Install sight's direct mount to the bow with (2) #10-24 x 5/8" flathead allen screws provided. **(See Figure 2)**
2. There are two sets of holes on the sight mount to allow you to move the sight in or out 3/4".
3. The 4 tapped holes to the rear are for a quiver mount, if desired.

For left-handed set-up:

1. Install sight and direct mount with windage clamp knob (B) on the bottom.
2. Remove the 2 level holder screws (Figure 1 D) (#5-40 x 5/16" socket head cap screws) from pin guard and reinstall them with the level and holder on the opposite side.

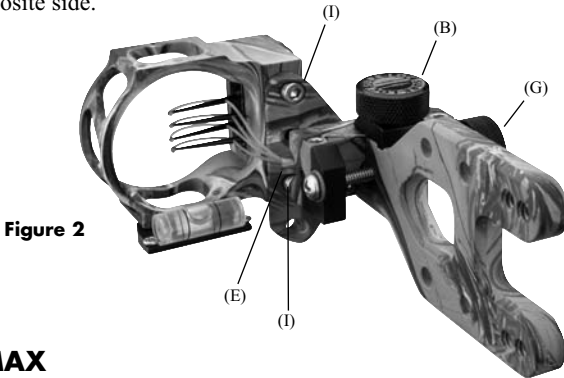

Figure 2

QC® MAX

1. Install slide direct mount to bow with (2) #10-24 x 5/8" flathead allen screws provided.
2. Use the (2) stand-offs and screws provided to mount a quiver to the slide direct mount. This will allow clearance for proper sight movement.

For left-handed set-up:

1. Install sight and slide direct mount with knobs on the bottom.
2. Remove the 2 level holder screws (D) (#5-40 socket head cap screws) from the pin guard and reinstall them with the level and holder on the opposite side.
3. Remove stop knob (M)—see Figure 4C on page 6—and stop assembly and reinstall on opposite side.



Figure 3

SET-UP AND ADJUSTMENT

3-Axis Leveling (See Figure 4)

Method 1

1. For centerline arrow impact on severe up or downhill shots, you will need to shoot several arrows downhill, then several arrows uphill without moving the sight's windage.
2. Loosen both #5-40 level holder socket head cap screws (D).
3. Centerline miss adjustments are opposite for right- and left-handed use:

Right-handed:

A consistent downhill miss to the right or an uphill miss to the left indicates the level should be pulled toward you. A consistent downhill miss to the left or an uphill miss to the right indicates the level should be pushed away from you.

Left-handed:

A consistent downhill miss to the right or an uphill miss to the left indicates the level should be pushed away from you. A consistent downhill miss to the left or an uphill miss to the right indicates the level should be pulled toward you.

4. Re-tighten the level holder socket head cap screws (D).
Note: Adjusting in this manner will not affect your impact on level ground.
5. Repeat steps 2 through 4 until correct center-shot impact is attained.

Method 2

1. Hold a small level against pin adjustment track (K) on side of frame.
2. Point bow approximately 30° down angle.
3. Match QC® level to the small hand-held level by loosening both #5-40 level holder socket head cap screws (D) and pivoting the level bracket.
4. Re-tighten the level holder socket head cap screws (D).

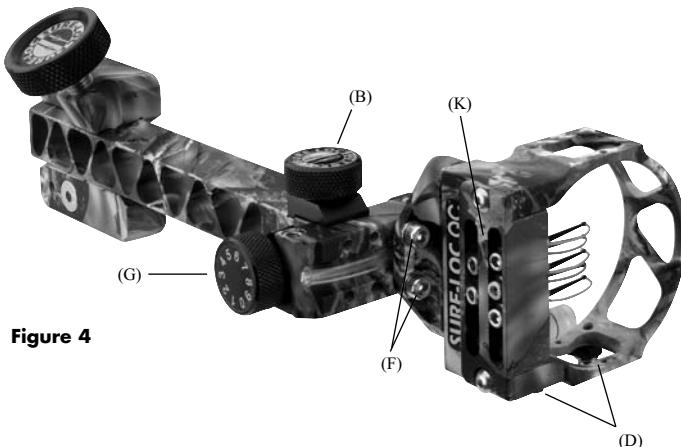

Figure 4

Windage adjustment (See Figure 4)

There is a total of about 1.50" of left and right movement.

Micro-adjust:

There is approximately .650" of micro movement.

Loosen locking clamp knob (B) and turn windage knob (G) to the desired position; then re-tighten locking clamp knob.

Mass-adjust:

There are (4) sets of holes to allow more movement left or right. The holes are 5/16" apart for a total of 15/16".

Loosen the (2) #6-32 screws (F) that mount the sight head to the windage and move to desired set of holes.

Elevation and pin adjustment (See Figures 4A / 4B / 4C)

Single pin adjustment

1. Loosen the #4-40 socket head cap screw (H) using a 3/32" hex allen wrench and slide to the desired position.
2. Tighten the #4-40 socket head cap screw. **(Do not over tighten.)**

Gang elevation adjustment

There are two locations for gang elevation adjustments: One is where the sight head connects to the offset bracket, for mass gang adjustments. The other is where the offset bracket mounts to the windage unit, for small slide elevation adjustments.

Mass elevation adjustment:

1. Remove the (2) 6-32 x 3/8" socket head cap screws (F) that attach the head to the windage unit.
2. Remove the (2) #6-32 socket head cap screws (I) that retain the offset bracket to the head.
3. Adjust the offset bracket to the desired position up or down and replace the offset bracket screws (I).
4. Reassemble the head to the windage unit.

Slide elevation adjustment:

1. Loosen the (2) 6-32 x 3/8" socket head cap screws (F) that attach the head to the windage unit and slide the head up or down to the desired position. There is a total of 5/16" movement.
2. Re-tighten the 6-32 socket head cap screws.

Figure 4A

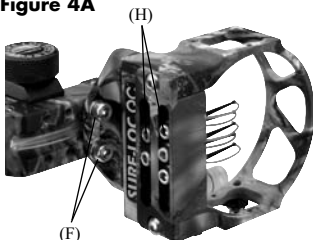
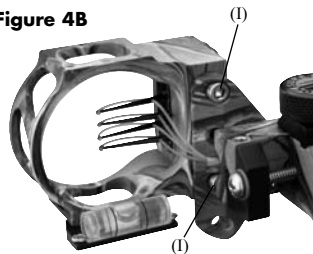

Figure 4B



QC® MAX

1. Use the same elevation and pin adjustments described previously. But before starting, loosen 3/4" lock knob (L) and position the slide toward the bottom of the slide travel.—This will allow for the maximum adjustment of yardage on the slide. **Note:** If needed, use the mass adjustment of the offset bracket to get the pin in the position of the sight window that's preferred.
2. Slide elevation adjustment:
 - a. With the pins set (example 20, 30, 40 yards or your choice), loosen small knob (M) on the stop and position it to the bottom of the long slide arm. **Note:** The stop will allow the sight to be moved for longer yardage and, when returned to the stop, the pins will be in their starting (example 20, 30, 40 yards) position.
 - b. To adjust for longer yardage: Using the bottom pin as the sight pin, loosen the 3/4" lock knob (S) and slide up—which moves the pin down—to the desired yardage and mark the sight tape. Continue this step until all the yardages needed are achieved. **Note:** Always lock knob before shooting.
 - c. Loosen 3/4" lock knob (S) and return it to the stop: The pins are back in their starting position. (Example 20, 30, 40 yards)

Depending on the speed of your bow, yardages of 100 plus can be achieved. **(USING THESE YARDAGES FOR HUNTING SITUATIONS ARE NOT RECOMMENDED UNLESS YOU ARE CAPABLE OF MAKING A CLEAN KILL SHOT WITH THEM.)**

Figure 4C

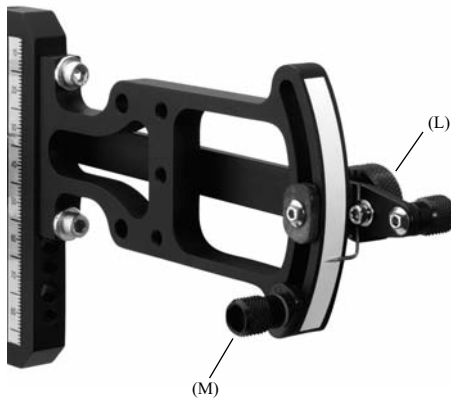

SURE-LOC® QC® MODULES

The SURE-LOC® QC® hunting sights use a modular pin block. Using extra QC® Modules—available separately—allows the archer to quickly change pin set-ups.



QC® Module removal (See Figure 5)

1. Remove the (2) #5-40 x 1/4" button head cap screws (J) with a 5/64 hex allen wrench.
2. **Take care to protect the fiber optics when removing the module.** Slide the module out of the pin guard frame, while carefully pulling the fibers out of the tube mounted in the windage block channel (C). **(Do not remove the tube.)**

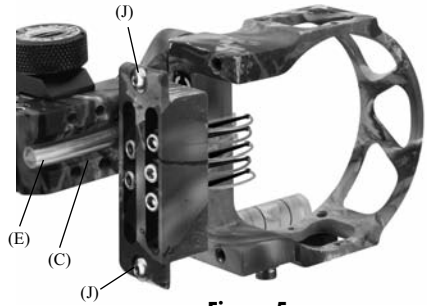

Figure 5

QC® Module assembly (See Figures 5 and 5A)

1. Place module into the pin guard and install the (2) #5-40 x 1/4" button head cap screws (J).
2. Install the number of pins desired using #4-40 x 5/16" socket head cap screws and a square washer. Alternate pin positions using the front and rear slots, making sure the fiber hole in the pin is facing toward the shooter.
3. Using heat source (**do not use open flame**) no hotter than 160°F, carefully expand one end of new fiber. A slight flare is enough to keep the fiber from slipping out of the pin.
Note: For best light gathering capabilities, smooth end of fiber while hot.
4. Slip the unexpanded end of the fiber through the end pin hole until the flared end is close to the pin.
5. Insert the fiber through the other pin hole. Gently pull fiber through and carefully push on the looped part of the fiber, until you get a loop that is about 3/16" to 1/4" from back of pin. **(Be careful not to kink fiber.)**
6. Repeat steps 3-5 for remaining pins.
7. Slide the long end of the fiber through the clear tube (E) in windage block channel (C). It will extend beyond the tube. Trim fiber to desired length.

Installing previously assembled QC® Module

(See Figures 5 and 5A)

1. Place the clear tube of the module that you are going to install onto the fibers of the removed module. This will protect the fibers from damage during storage.
2. Slide previously assembled module into pin guard frame, with loose ends of the fiber optics pointing through head towards back of sight.
3. Start the long fiber ends into the tube (E).
4. Re-install the (2) button head cap screws (J).
5. Carefully slide the fiber the rest of the way into the tube.
6. Trim fiber to desired length.

Figure 5A

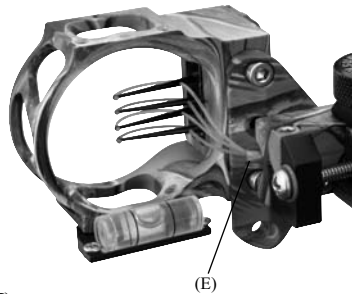

LENS ADAPTER/CHOKE TUBE

This accessory allows you to use the Black Eagle 42mm lens on the QC® 1, 2 and MAX (Model 200 only).

1. Slide adapter into pin guard.
2. Fasten on top and bottom with provided screws.
3. Screw lens clockwise into adapter.



Lens Adapter/Choke Tube shown with Lethal Weapon® frame

Use the choke tube alone to provide extra protection for your pins and reduce the viewing diameter from 2" to 1 11/16".

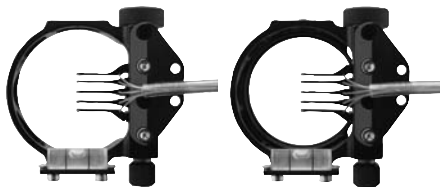

Lethal Weapon® frame shown without and with Choke Tube

LIGHT KIT FOR SURE-LOC® QC® 1, 2 AND MAX

This fingertip controlled, brightness adjustable light can be mounted so it aims up or down on your fibers.

Mounting instructions

On top shining down:

1. Place the light/bracket assembly on the top of the pin guard with the nose of the light pointing down.
2. Install the (2) 5-40 socket head cap screws and washers.
3. Tighten screws.

Note: When using a lens adapter/choke tube, mount the light on top with its nose toward the archer.

On bottom shining up:

1. Remove level and bracket.
2. Remove level from the bracket—retain the level and screws for the next step.
3. Install the level and screws to light/bracket assembly.
4. Place the light/bracket assembly on the bottom of the pin guard with the nose of the light pointing up.
5. Install the (2) 5-40 socket head cap screws and washers and tighten screws.



Adjustable brightness operation

1. Press button to turn light on or off.
2. Press and hold button to control brightness.

From off:

- Release at desired brightness. Light will blink at full brightness.

From on:

- Release at desired dimness. Light will blink at lowest light level.
3. For safety beacons, patiently press button and hold past blink. You can choose slow beacon, medium beacon, fast flash, or S.O.S.

Note: If light turns on properly, but then turns off by itself, the light is in “demo” mode. To remove “demo” mode, turn light back on; then simply press and hold button until light turns off—about 20 seconds. Continue with normal operation.

Battery replacement

1. Carefully pry up on the light housing and remove from bracket/cap.
Note: The light housing detaches from the light cap and bracket assembly, which both stay on the sight.
2. Replace with (2) cr-2016 Lithium batteries. Install the (+) side toward the cap. Be sure top of battery is under the metal strap.
3. Replace the light housing and snap shut.

Note: In the event of water penetrating the light case, simply open the case and allow to dry.



Warranty

All SURE-LOC archery products (with the exception of film-dipped finish, fiber optic pins and scope lenses) are guaranteed against defects in both workmanship and materials for two years from the date of purchase. After the two-year warranty period is over, repairs and replacements will be subject to charge. Please call C.S. Gibbs Corporation at 812/689-9926 to determine what the charge might be.

C.S. Gibbs Corporation or an authorized SURE-LOC dealer **MUST** perform any warranty work. In the event the product needs to be returned to C.S. Gibbs Corporation, please contact C.S. Gibbs Corporation Customer Service for a RETURN AUTHORIZATION (RA#) NUMBER and shipping instructions. A RETURN AUTHORIZATION (RA#) NUMBER must be obtained by calling C.S. Gibbs Corporation at 812-689-9926 between the hours of 8AM and 4:30PM EST. Please send accompanying documentation, such as dated sales receipt showing the purchase date of the product and a short note explaining the nature of the problem. The RA# you are given must be written on the outside of the shipping container.

Any evidence of modification or abuse will void the warranty. If a repair charge is necessary, the customer will be notified prior to the repair.

C.S. Gibbs Corporation makes no other claims either expressed or implied. In the interest of product improvement and consumer safety, C.S. Gibbs Corporation reserves the right to make changes in product design, color and specifications without notice.

US Patent Pending
Copyright © 2009 C.S. Gibbs Corporation

PUB# PF43325—0509

SURE-LOC[®]

ARCHERY PRODUCTS

C.S. Gibbs Corporation
100 W. Quality Lane, Versailles, IN 47042
phone 812/689-9926 • fax 812/689-9927
www.sureloc.com